

| REV. | DESCRIPTION | DATE |
|------|--------------|------------|
| A | BRAND UPDATE | 09/01/2020 |

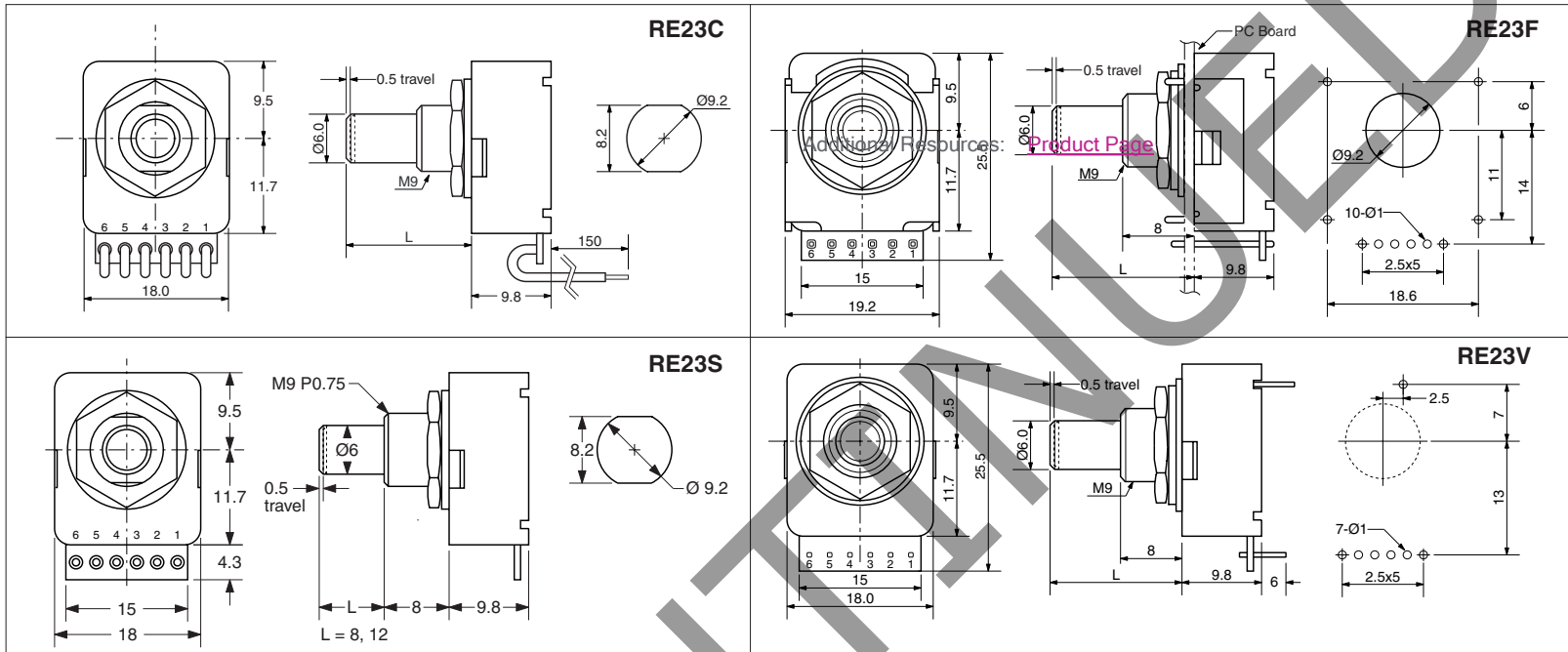

SPECIFICATIONS

ELECTRICAL

- Input Power: 5.0 VDC $\pm 10\%$ @ 10mA
3.3 VDC $\pm 10\%$ @ 10mA
- Output Voltage: H = Vcc - 0.4V
L 0.4V
- Resolution: 16, 25 PPR
- Output Type: TTL/CMOS Compatible
- Max. Freq. Response: 500 Hz
- Push switch rating: 12VDC@20mA max.

MECHANICAL

- Max Shaft Load, radial: 1.0 kgf
axial: 1.0 kgf
- Rotational Angle: 360° continuous
- Click Torque: 100 gf cm max.
- Push switch actuation force: 300~700gf
- Rotational Life: 2.5 x 10⁶ cycles

ENVIRONMENTAL

- Operating Temp: 0° to +60° C
- Storage Temp: -20° to +80° C
- Humidity: 85% RH, no condensation
- Vibration: 10~55 Hz, 1.5 mm, 2 hrs
- Shock: 50G, 6ms, 3 axes, 3 reps

OUTPUT CIRCUIT

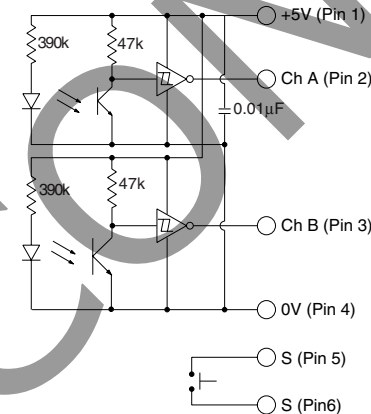

OUTPUT WAVEFORM

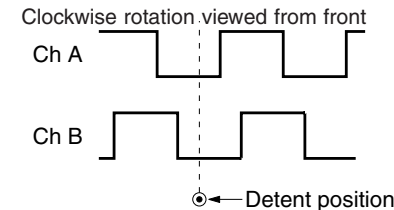

ORDERING INSTRUCTIONS

RE23X X XX C XXRX

Type: _____
N: Non-Drip Proof

Termination Options: _____
S: Solder Hole
C: Cable Type
V: Vertical Mount
F: Front Mount

Resolution:
16: 16 PPR
25: 25 PPR

Detent:
C: Detent Only

Input Voltage:
A: 5V $\pm 5\%$ input
B: 3.3V input

Shaft Length:
16: 16mm shaft
20: 20mm shaft

CUI Devices
6405 SW Rosewood St, Suite C
Lake Oswego, OR 97035
www.cuidevices.com

| | | | |
|-----------|--|--------------|----|
| TITLE: | panel mount optical encoder, push switch | REV: | A |
| PART NO. | RE23XXXXCXXRX | UNITS: | MM |
| DRAWN BY: | JRH | APPROVED BY: | |
| | | SCALE: | |

