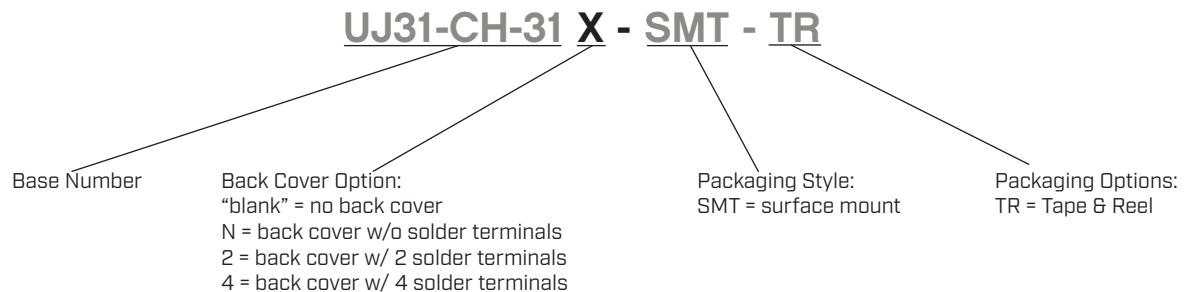

**SERIES:** UJ31-CH-SMT | **DESCRIPTION:** USB RECEPTACLE**FEATURES**

- USB Type C receptacle
- USB 3.2 Gen 2
- 10 Gbit/s data transfer speed
- reflow solder compatible
- tape & reel packaging

**PART NUMBER KEY****SPECIFICATIONS**

| parameter                       | conditions/description                            | min | typ    | max  | units  |
|---------------------------------|---|-----|--------|------|--------|
| USB standard                    | USB 3.2 Gen 2                                     |     |        |      |        |
| rated input voltage             |   |     |        | 20   | Vdc    |
| rated input current             | as per EIA-364-70, Method B                       |     |        |      |        |
|                                 | power pins collectively [A4, A9, B4, B9]          |     |        | 5.0  | A      |
|                                 | GND pins collectively [A1, A12, B1, B12]          |     |        | 6.25 | A      |
|                                 | VCONN pins individually [A5, B5]                  |     |        | 1.25 | A      |
|                                 | all other signal pins individually                |     |        | 0.25 | A      |
| contact resistance <sup>1</sup> | between terminals and mating plug                 |     |        | 40   | mΩ     |
| insulation resistance           | at 100 Vdc for 1 minute between adjacent contacts | 100 |        |      | MΩ     |
| voltage withstand               | at 60 Hz for 1 minute between adjacent contacts   |     |        | 100  | Vac    |
| insertion force                 | at a rate of 12.5 mm/min                          | 5   |        | 20   | N      |
| withdrawal force                | at a rate of 12.5 mm/min                          | 8   |        | 20   | N      |
| life                            | at a rate of 200 max cycles per hour              |     | 10,000 |      | cycles |
| operating temperature           |   | -30 |        | 85   | °C     |
| storage temperature             |   | -40 |        | 85   | °C     |
| flammability rating             | UL94V-0   |     |        |      |        |
| RoHS                            | yes   |     |        |      |        |

Note: 1. When measured at 20 mV max / 100 mA.

## MECHANICAL DRAWING

units: mm  
 tolerance:  
 X.X ±0.20 mm  
 X.XX ±0.15 mm

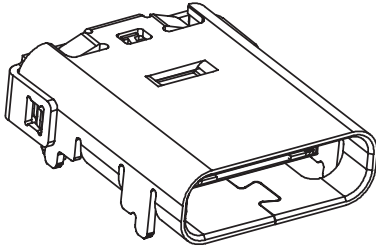

|                   | MATERIAL        | PLATING                           |
|-------------------|-----------------|-----------------------------------|
| contact terminals | copper alloy    | contact: 2 μ" gold<br>solder: tin |
| shell             | stainless steel | nickel                            |
| EMI shell         | stainless steel |                                   |
| mid plate         | stainless steel | tin                               |
| insulator         | PA9T            |                                   |

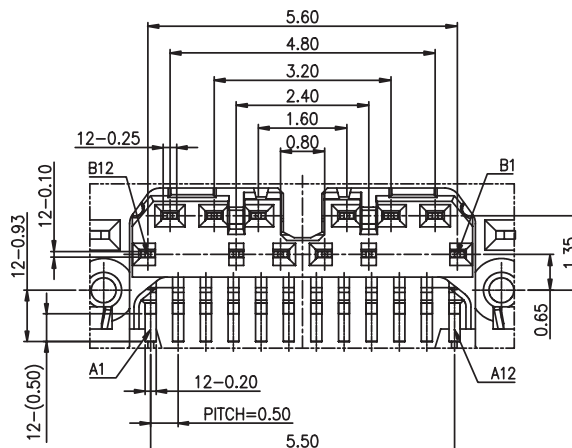
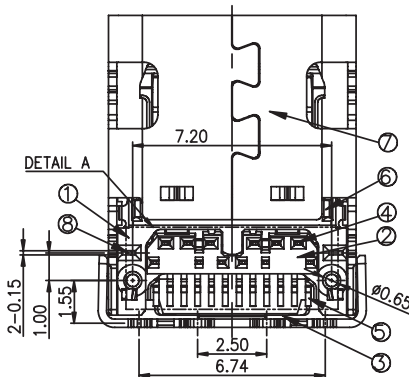
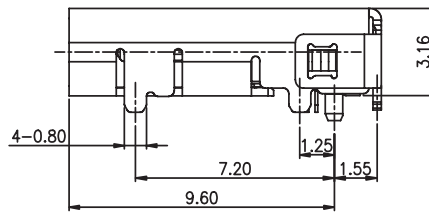
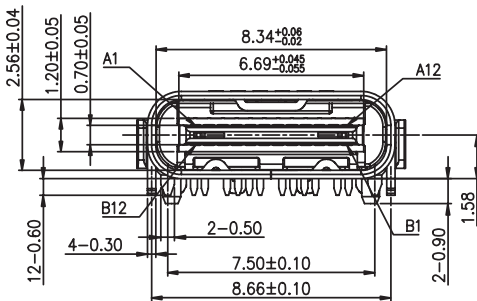
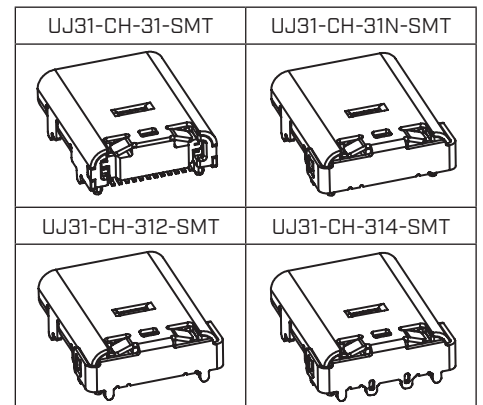
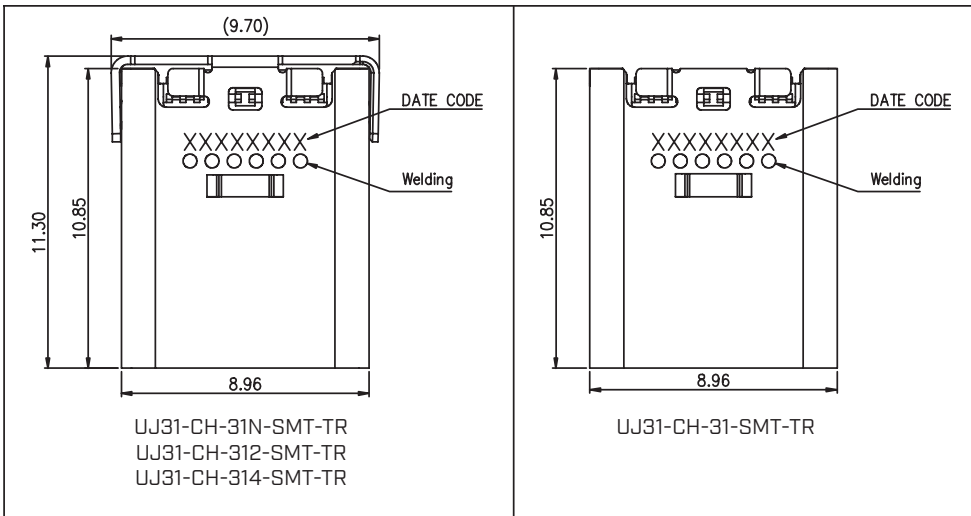

DETAIL A  
 SCALE: 8/1

## MECHANICAL DRAWING (CONTINUED)

units: mm  
PCB tolerance: ±0.05 mm

| PIN CONNECTIONS |                  |                 |       |                  |                 |
|-----------------|------------------|-----------------|-------|------------------|-----------------|
| PIN             | SIGNAL NAME      | MATING SEQUENCE | PIN   | SIGNAL NAME      | MATING SEQUENCE |
| A1              | GND              | FIRST           | B12   | GND              | FIRST           |
| A2              | SSTXp1           | SECOND          | B11   | SSRXp1           | SECOND          |
| A3              | SSTXn1           | SECOND          | B10   | SSRXn1           | SECOND          |
| A4              | V <sub>BUS</sub> | FIRST           | B9    | V <sub>BUS</sub> | FIRST           |
| A5              | CC1              | SECOND          | B8    | SBU2             | SECOND          |
| A6              | Dp1              | SECOND          | B7    | Dn2              | SECOND          |
| A7              | Dn1              | SECOND          | B6    | Dp2              | SECOND          |
| A8              | SBU1             | SECOND          | B5    | CC2              | SECOND          |
| A9              | V <sub>BUS</sub> | FIRST           | B4    | V <sub>BUS</sub> | FIRST           |
| A10             | SSRXn2           | SECOND          | B3    | SSTXn2           | SECOND          |
| A11             | SSRXp2           | SECOND          | B2    | SSTXp2           | SECOND          |
| A12             | GND              | FIRST           | B1    | GND              | FIRST           |
| SHELL           | GND              |                 | SHELL | GND              |                 |

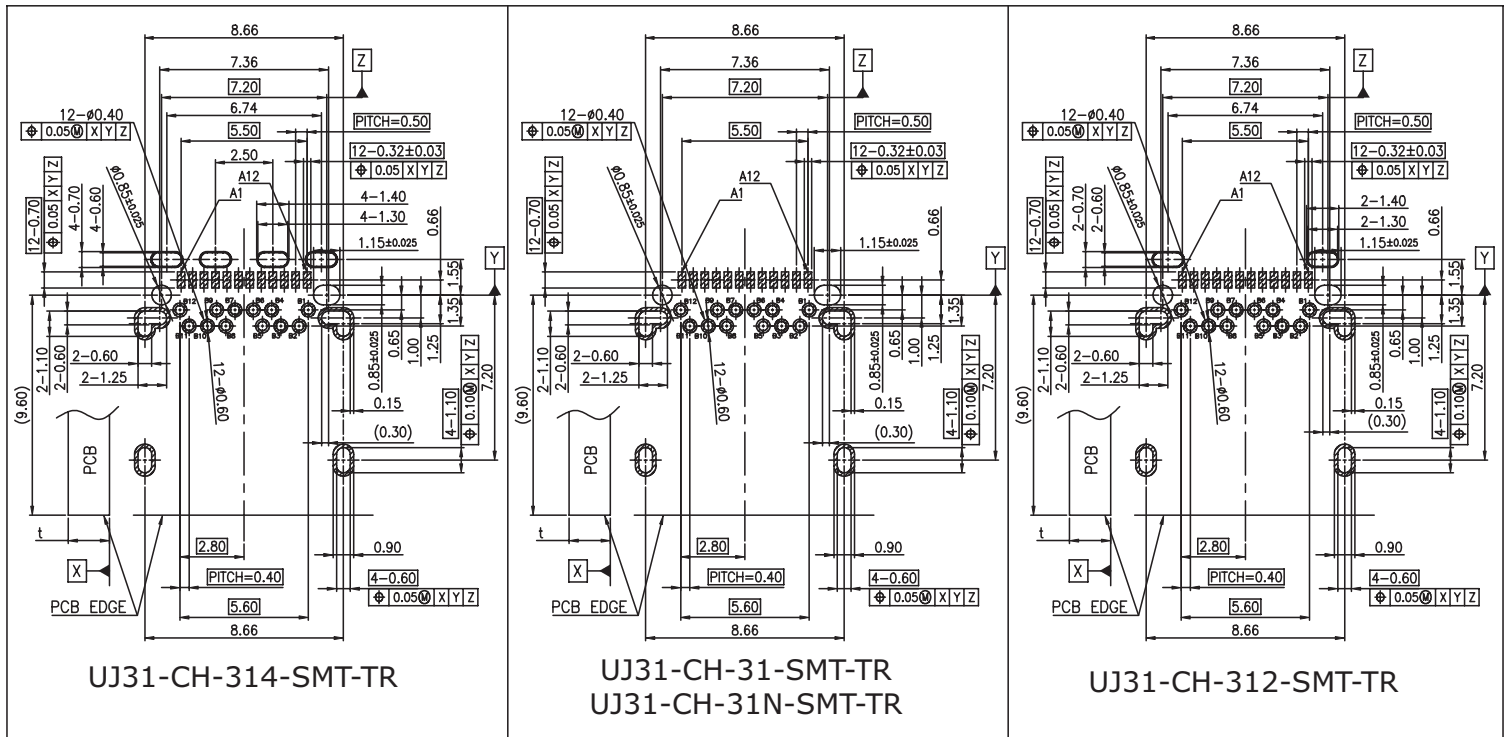

Recommended PCB Layout  
Top View

## SOLDERABILITY

| parameter                     | conditions/description    | min | typ | max | units |
|-------------------------------|---------------------------|-----|-----|-----|-------|
| reel storage                  | at relative humidity <60% |     |     | 30  | °C    |
| reflow soldering <sup>1</sup> | see reflow profile        | 255 | 260 | 265 | °C    |

Note: 1. It is recommended to reflow solder within 168 hours from opening vacuum packaging at a temperature <30°C & relative humidity <60%.

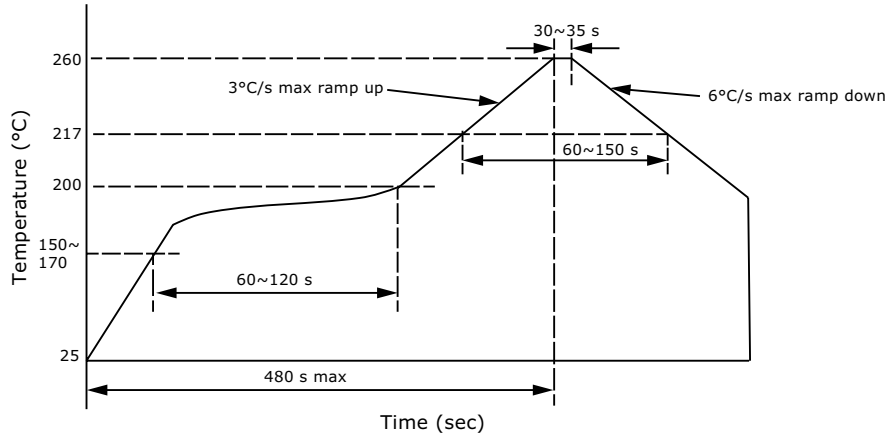

## PACKAGING

units: mm

Reel Size: Ø380 mm

Reel QTY: 1,200 pcs per reel

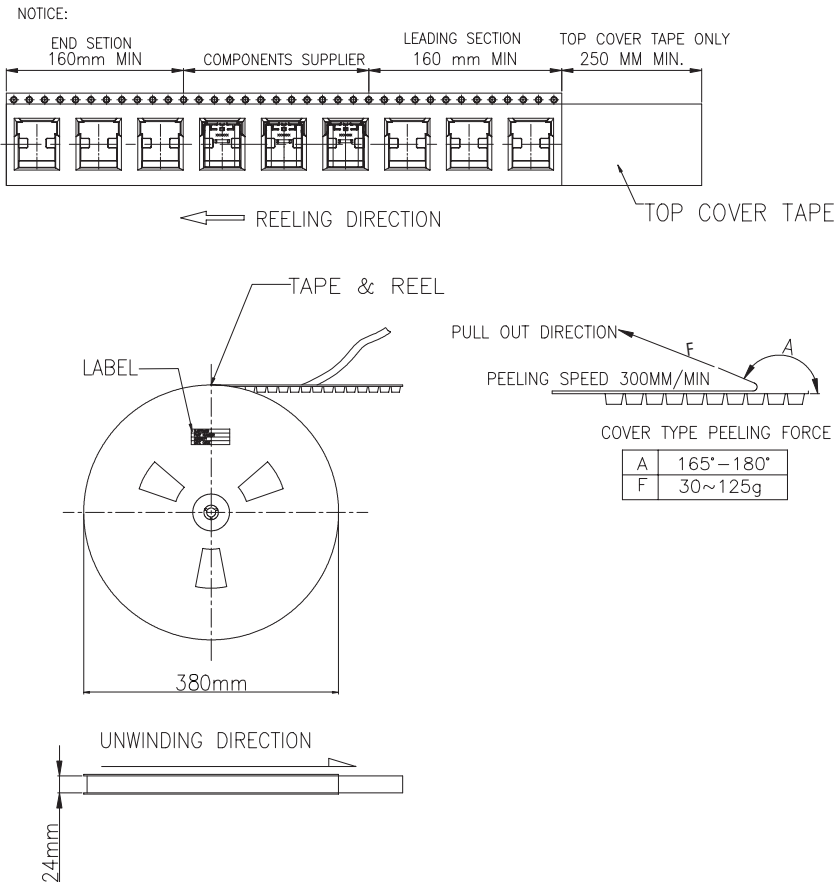
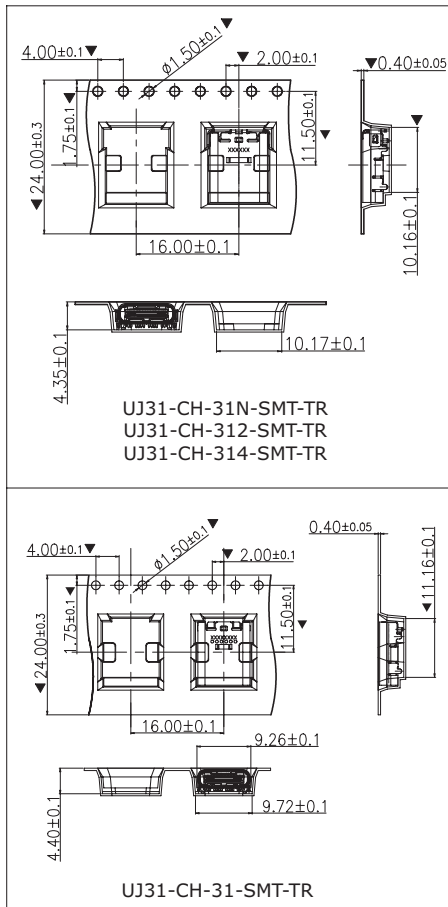

## REVISION HISTORY

| rev. | description                  | date       |
|------|------------------------------|------------|
| 1.0  | initial release              | 12/19/2017 |
| 1.01 | updated reel details         | 01/19/2018 |
| 1.02 | updated datasheet            | 01/30/2018 |
| 1.03 | brand update                 | 01/28/2020 |
| 1.04 | updated USB standard         | 04/19/2022 |
| 1.05 | logo, datasheet style update | 08/05/2022 |

The revision history provided is for informational purposes only and is believed to be accurate.



CUI Devices offers a one (1) year limited warranty. Complete warranty information is listed on our website.

CUI Devices reserves the right to make changes to the product at any time without notice. Information provided by CUI Devices is believed to be accurate and reliable. However, no responsibility is assumed by CUI Devices for its use, nor for any infringements of patents or other rights of third parties which may result from its use.

CUI Devices products are not authorized or warranted for use as critical components in equipment that requires an extremely high level of reliability. A critical component is any component of a life support device or system whose failure to perform can be reasonably expected to cause the failure of the life support device or system, or to affect its safety or effectiveness.

[cuidevices.com](http://cuidevices.com)